

The Linatron® M™ is a modular system. The control console, modulator, and RF unit are common to all model configurations. Only the X-ray head changes to match the application. The Linatron - M is designed to fit mobile, gantry, and fixed installations.

1.0 Standard Equipment and Services

1.1 Control Console

The standard control console is a touch screen display system.



1.2 X-ray Head Low Leakage (0.1%)

1.3 Modulator/Power Distribution Cabinet External signal interface.

1.4 Temperature Control Unit (TCU)

The TCU is used to keep the system components at a nominal 30°C (86°F). It is available in high voltage and low voltage configurations for environments ranging from -40/+55°C (-40/131°F), condensing.

1.5 Standard Spare Parts Kit

The spare parts kit includes items such as PCBAs and individual components.

1.6 Interconnecting cables and hoses included with lengths up to 100 meters.

1.7 Manuals

Operator Manuals are included in English.

1.8 Installation Supervision and Startup * Radiographic Optimization available.

1.9 One Year Warranty

Service includes inclusive parts and labor up to one year.

2.0 Performance

X-ray Head and RF Unit



2.1 X-ray Beam Quality

The X-ray beam quality is derived from a compilation of broad beam data measurements.

Model	Nominal Energy (MeV)	Flatness (% @ ± 7.5°)	Max. Dose Rate (Gy/Min)
M3	1.0	≥87.0	0.25
	2.0	≥78.0	2.0
	3.0	≥72.5	3.0

2.2 X-ray Beam Dose Rate* (10 cm x 10 cm field) the maximum continuous dose rate at 1 meter is listed in Table 1 (without flattening filter) at Beam Centerline. Dose rate is reduced with flattening filter.

2.3 X-ray Field Size

A 30° cone or 22.5° square defines the field. Also see section 4.1. Custom collimators are available upon request.

2.4 X-ray Beam Focal Spot Size

The focal spot size does not exceed 2.0 mm in diameter. Smaller spot sizes are available at reduced dose output.

2.5 X-ray Beam Symmetry

The beam asymmetry does not exceed 5% at ±7.5° off the central axis for all energies.

2.6 Standard Leakage Radiation

The leakage radiation is specified along the horizontal plane at 1 meter from the beam centerline at angles 60° and greater, outside the primary beam. The values are a fraction of the primary beam central axis dose rate measured with a 10 cm x 10 cm collimator; 1x10⁻³. Leakage radiation does not include primary beam scatter. See section 4.2 for lower leakage options.

3.0 Customer Facility Requirements

3.1 Electrical Requirements

The Linatron M operates from a single 15 kVA 50/60 Hz power source. Two voltage ranges are available.

3.1.1 Low Voltage Option

208 VAC, 3 phase, 3 or 4 wire plus ground, 60 Amp minimum surge per leg. ± 10% voltage regulation is required.

3.1.2 High Voltage Option

400 VAC, 3 phase, 4 wire plus ground, 40 Amp minimum surge per leg. ± 10% voltage regulation is required.

3.2 The TCU is connected to a separate 13-kVA power source. Models are available that can operate on a line voltage of 220 VAC and 400 VAC, at 50Hz; or 220 VAC and 480 VAC, at 60Hz. A separate 10- kVA power source may be required for the in-line heater package.

3.3 Operating Environment

3.4 Indoor Requirement

3.4.1 The operating environment

The indoor requirement for control console and modulator must be between 4°C (39°F) and 35°C (95°F), with 90% maximum relative humidity (non- condensing).

3.4.2 Outdoor Requirement

The available temperature range for X-ray head / RF unit is dependent on the TCU and thermal insulation blanket. The range can be absorbed as -40/+55°C (-40/131°F), condensing.

3.4.3 Ventilation

The appropriate heat given to room air from each component with system operating at full power is given below:



X-ray Head/RF Unit: 1.0kW
 Modulator Cabinet: 2.0 kW
 Temperature Control Unit: 6.0-12.0 kW
 Touchscreen Control Console: Negligible

4.0 Optional Equipment

4.1 Custom Beam Collimation

Nonstandard field sizes are available per customer's requirements. A motorized collimator is also available to quickly change the beam collimation.

4.2 Lower Leakage Options listed in Table 2

Table 2			
Model	Leakage (Fraction)		
M3	Standard	Super Low	Ultra Low
		1x10 ⁻³	2x10 ⁻⁵

4.3 Voltage Regulator

Recommended for installations where line power short-term fluctuations are greater than +/-5%. A step-up or step-down transformer can also be ordered to adapt a non-standard voltage source for use with the Linatron or TCU. The regulator is CE and UL approved.

4.4 Beam Flattener

This option provides a more uniform beam intensity over the exposed region at 3.0 MeV. Use of a flattening filter will reduce dose rate.

4.5 Dual Energy

The dual energy specifications are given in Table 3. Select two operating energies:

Table 3			
Model	Nominal Energy (MeV)	Flatness (% @ ± 7.5°)	Max. Dose Rate (Gy/Min)
M3A*	1.0	≥82.0	0.25
	2.0	≥78.0	2.0
	3.0	≥72.5	3.0

* M3A ULLP only available with 2 and 3 MeV

4.6 Laser Alignment System

An internally mounted single spot laser is available to align the X-ray beam to an object being radiographed. Not available with ULLP leakage option. ULLP shielding option is unavailable with the laser option. Laser is 533 nm, Class II, 0.5 mW.

4.7 Variable External Collimator

The dependent jaw variable external collimator mounts to the front of the X-ray head. The field size varies between 1° and 24°. A rotating version is available that rotates over a range from -50° to +50°.

External Collimator with Rotation



4.8 Remote Customer interface Signals include:

- External Trigger
- Emergency Off
- Remote Interlock
- Warning Lights
- Warning Alarm
- X-ray on Request
- Warm Up and Power On Status
- Fault Information and Reset

4.9 Smart Remote Customer Interface

The Linatron uses industry standard Modbus TCP Client/Server Protocol. The customer can use a personal computer or utilize a primary control system to control/monitor the Linatron. The signals available include control, fault monitoring and analog input signals.

Quality

Varex Imaging Corporation, Las Vegas is an ISO 9001 registered facility.

Regulatory Compliance CE Marking

All M-Series Linatron models have been tested and meet all Varex Imaging Quality specifications and are in conformity with following standards for safety and EMC requirements and in compliance with the European Union Directives regarding CE marking.

Safety

IEC / EN 61010-1:2010, Ed: 3 Safety requirements for electrical equipment for measurement, control, and laboratory use
ANSI / UL / CSA C22.2 No. 61010-1-12, Ed: 3

Electromagnetic Compatibility (EMC)

FCC CFR Title 47 Part 18 Rules
Conducted & Radiated Emissions
CISPR 11 / EN 55011:2009+A1:2010
Conducted & Radiated Emissions

European Union Directive

2014/35/EU Low Voltage Directive
2014/30/EU EMC Directive
2011/65/EU Reduction of Hazardous Substances (RoHS)

M3 PHYSICAL CONFIGURATIONS

Control Console
(9 lbs)

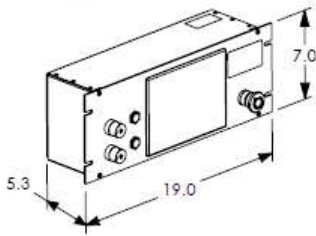

100015308 - M3 SUPER LOW LEAKAGE			
PARAMETERS	X	Y	Z
CENTER OF GRAVITY	16.8	10.5	13.1
FOCAL POINT	9.6	9.5	9.3
TOTAL WEIGHT: 2010 ± 25 LBS			

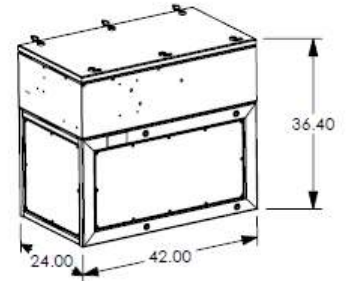

Modulator
(735 lbs)

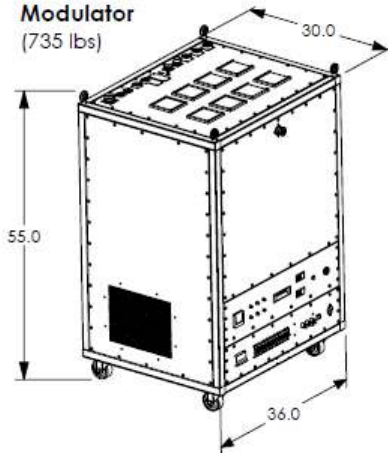

100015310 - M3 LOW LEAKAGE			
PARAMETERS	X	Y	Z
CENTER OF GRAVITY	18.0±.5	10.8±.5	14.4±.5
FOCAL POINT	9.6	9.5	9.3
TOTAL WEIGHT: 1920 ± 25 LBS			

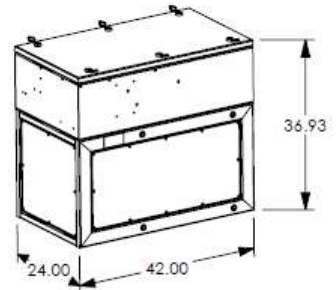

100018987 - M3 ULTRA LOW LEAKAGE			
PARAMETERS	X	Y	Z
CENTER OF GRAVITY	17.6	16.0	13.4
FOCAL POINT	9.8	15.6	9.5
TOTAL WEIGHT: 5175 ± 25 LBS			

